

QH10SWAP

QH SERIES

QH10SWAP featured 18inch low-frequency transducers with high-power configuration. Profit by cabinet natural extension of the transmission line design, effectively increase and improves the low-frequency response and sensitivity, without any other increase other subwoofer extra burden can be reach to 98dB, maximum 132dB. QH10SWAP featured CLASS-D AMP, provided small size, light weight, high efficiency, lower exothermic characteristic. Configuration work with QH10SW to extend Low-frequency. QH10SWAP also featured DSP processor with processing parameters, can obtain carefully processed frequency response, corrected phase.



Acoustic Performance

System	Subwoofer
Frequency Range (-10dB)	32Hz-300Hz
Frequency Range (±3dB)	38Hz-200Hz
Rated Power	600W
Maximum Power	2400W
Sensitivity(1w/1m)	98dB
Maximum SPL	132dB
Loudspeakers	1x18"
X-over	120Hz/24dB/octave
Nominal Impedance	8Ω
Connections	2xNLT4 ±1BASS/±1LF/±2HF

Physical Performance

Hoisting Way	Hoisting with 4
Size(WxDxH)	575x780x600(mm)
Weight	N.W:56.5kg R.W:60.5kg

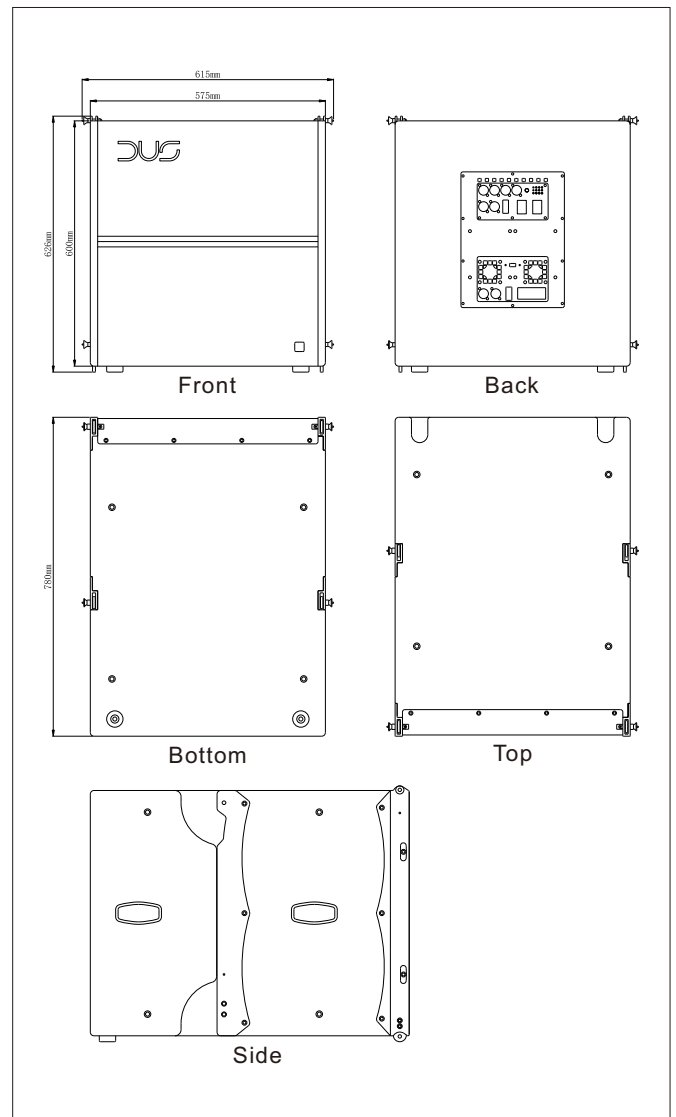

Frequency Response&Impedance

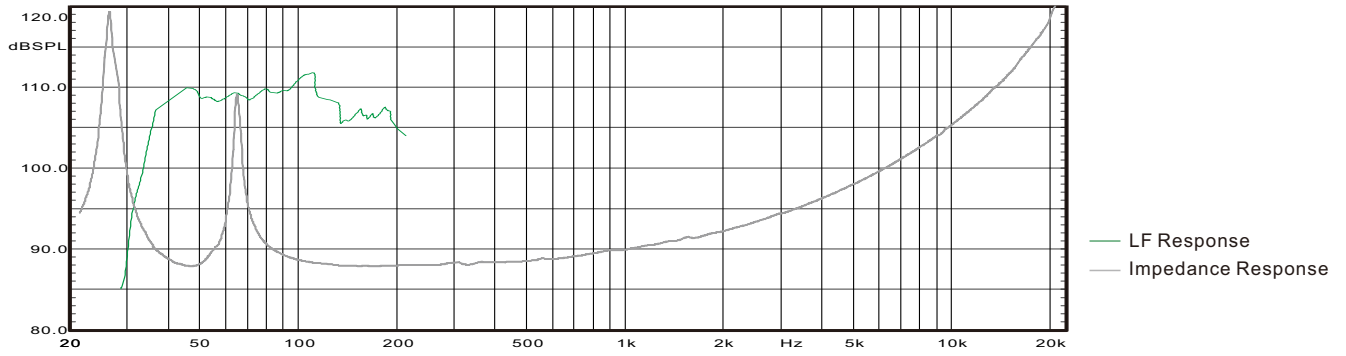

Phase Curve

