

Q05

Q SERIES

Q05 line array full range speaker featured dual 5inch low-mid transducers and a 1inch ND compression driver that have been designed focused on middle to small size venues. Optimized driver placement and the HF wave guide throughout the Q series makes Q05 speaker resulted a consistency 100-degree horizontal coverage and a higher slope attenuation at vertical direction.

Q05 speaker has built-in rigging hardware for easily setup that can be done even by only one engineer. Flexible configurations makes Q05 speaker can be used as traditional line array system for longer throw or as a standalone full range point source speakers for some applications like stage front-fill, under balcony fills when work with other Q series as a left right main system. Q05 speaker can be widely used for middle to small size theatre, school, auditorium, sports, hotel ballroom, small Live House venue, and theme park applications.



Acoustic Performance	
System	2-way line array loudspeaker
Frequency Range (-10dB)	80Hz-20kHz
Frequency Range (± 3 dB)	100Hz-18kHz(LF)
Dispersion Angle	100°x 9°(HxV)
Rated Power	240W
Maximun Power	960W
Sensitivity(1w/1m)	94dB
Maximum SPL	124dB
Loudspeakers	LF:2x5" HF:1x1"Neodymium
X-over	100kHz/24dB/octave
Nominal Impedance	16 Ω
Connections	2xNLT4 \pm 1

Physical Performance	
Hoisting Way	Hoisting with 3
Size(WxDxH)	446x304.5x219(mm)
Weight	N.W:12.2kg R.W:16.5kg

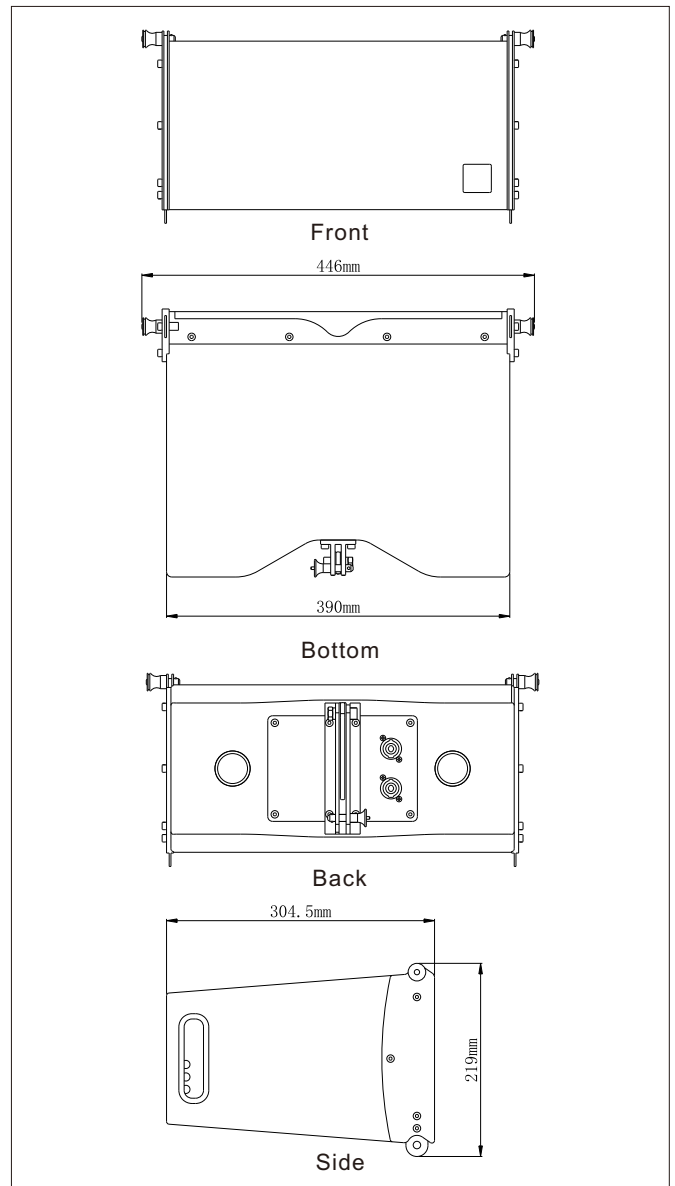

Frequency Response & Impedance

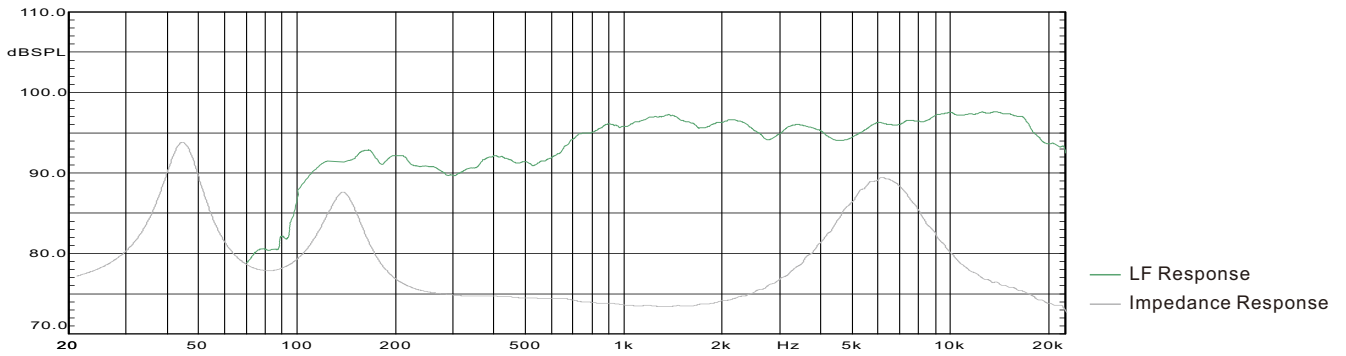

Frequency Response in Horizontal

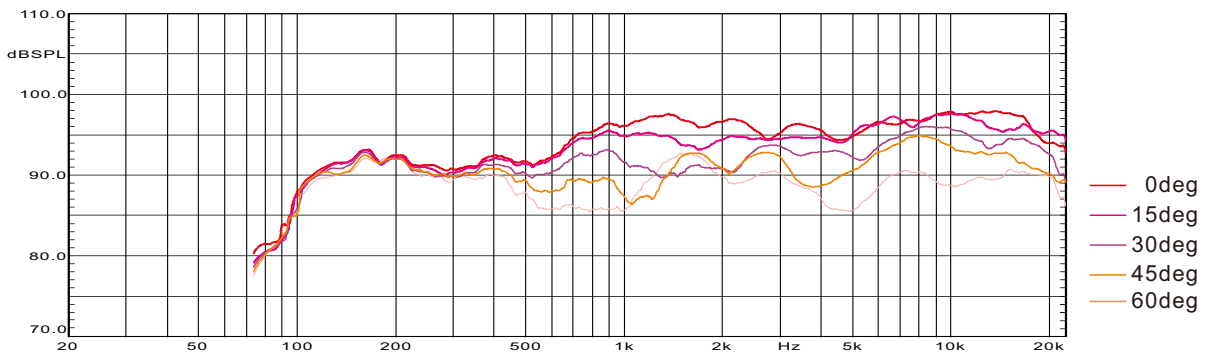

Frequency Response in Vertical

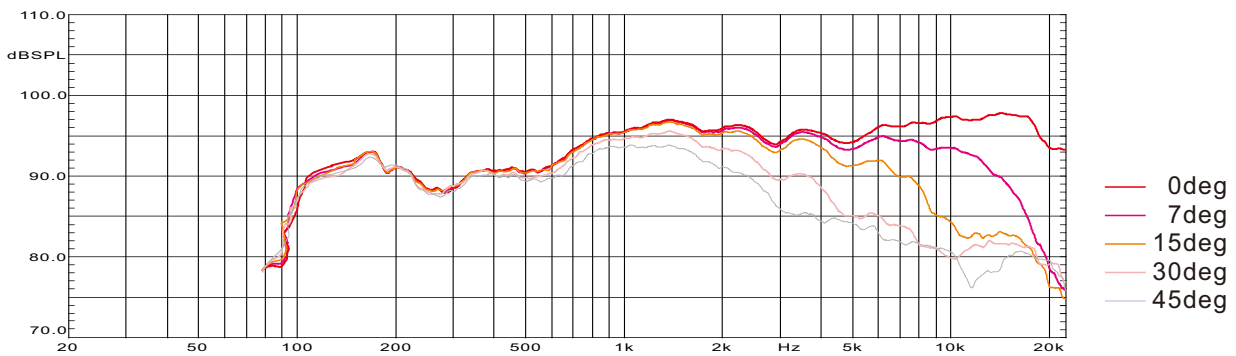

Phase Curve

